

vft
black line
pumps



Black Hawk
BH4-18

Black Hawk BH4-18

Up to 28,8 bar and 397 l/min

The BH4-18 is part of the Black Hawk line of portable vft fire pumps, powered by 18 hp Briggs and Stratton Vanguard "V twin" air cooled engine with over-speed protection that combined with a VFT_INCREASER and VFT_4SP pump offers an excellent power to weight ratio, low noise level and a easy starting.

This powerful combination is capable of delivering very high pressures and has the ability to perform long hose runs without lose of performance.

- > High-quality components and spare parts availability
- > Best Quality/Price ratio.
- > 2 years warranty.



Applications

- Direct attack with hose laying.
- Self-protection maneuvers with sprinklers.
- Tandem pumping of motor pumps over long distances.

Features

- Electric start (battery optional) with manual recoil backup.
- Compact and resistant, with easy portability.
- Constructed in high quality materials, ensuring a long lasting use.
- Interchangeable VFT_4SP pump coupled with V-Clamp stainless steel quick release system (compatible with foam).
- Maintenance-free speed increaser. Made of cast aluminum and high quality components.
- Choice of hand carrying tube frame (with gripping points for easy transport) or channel base frame for vehicle mount.
- Optional integral fuel tank.
- Hand priming pump and pressure gauge included.
- Non-return discharge valve included

Specifications

Motor	Briggs and Stratton Vanguard 18HP
Centrifugal Pump	VFT 4 stage
Weight	68.5 kg (dry)
Maximum Pressure	28.8 bar
Maximum Flow	397 l/min
Sizes	Length: 83 cm. Wide: 49.5 cm. Height: 48 cm.

1. Engine BRIGGS AND STRATTON 18HP VANGUARD



Motor Specifications

Motor	4 strokes gasoline
Bore x Stroke	72,2 X 70 mm
Displacement	570 cm ³
Compression ratio	8.2 : 1
Power	18HP
Nº Cylinders	2
Starter	Manual starter with manual recoil rope and electric start.
Oil sensor	Yes
Engine oil capacity	1,7 L
Dimensions (l. x w. x h.)	318 mm x 410 mm x 438 mm
Dry weight	35 kg

2. Centrifugal 4 stage Pump (VFT4SP)



The VFT4SP is a compact, efficient and reliable 4-stage centrifugal pump.

The pump body and impellers are made of aluminum with anti-corrosion treatment. The shaft and other components are made of stainless steel. Incorporates a high quality mechanical seal specifically designed.

*Pump compatible with foam.

VFT4SP Specifications

Suction	2" NPSH
Impulsion	1,5" NPSH

3. BH4-18 Performance

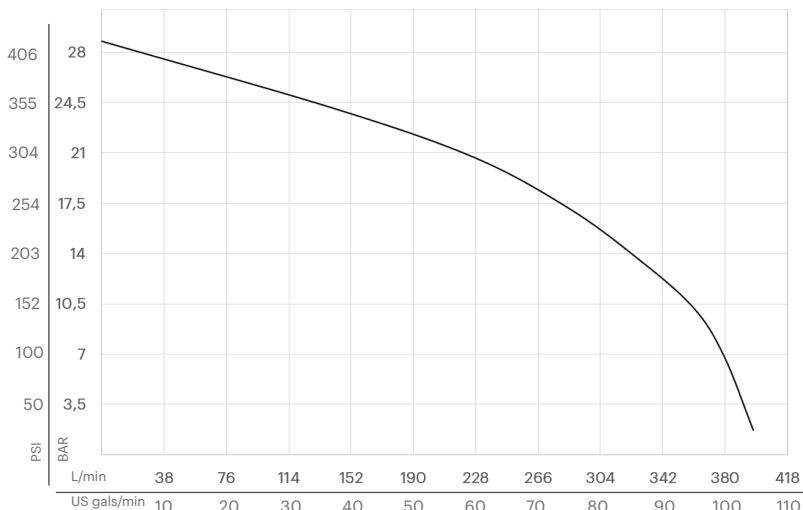

Max. Performance

Max. Flow	397 l/m
Max. Pressure	28.8 bar
Max. Water Gauge	294 mH2O

Pressure		Flow	
[Bar]	[PSI]	[L/Min]	[U.S. GPM]
24.1	349.5	142	37.5
13.8	200	325	86
3.5	50	394	104

4. Technical drawings

Length: 83 cm. | Wide: 49,5 cm. | Height: 48 cm.

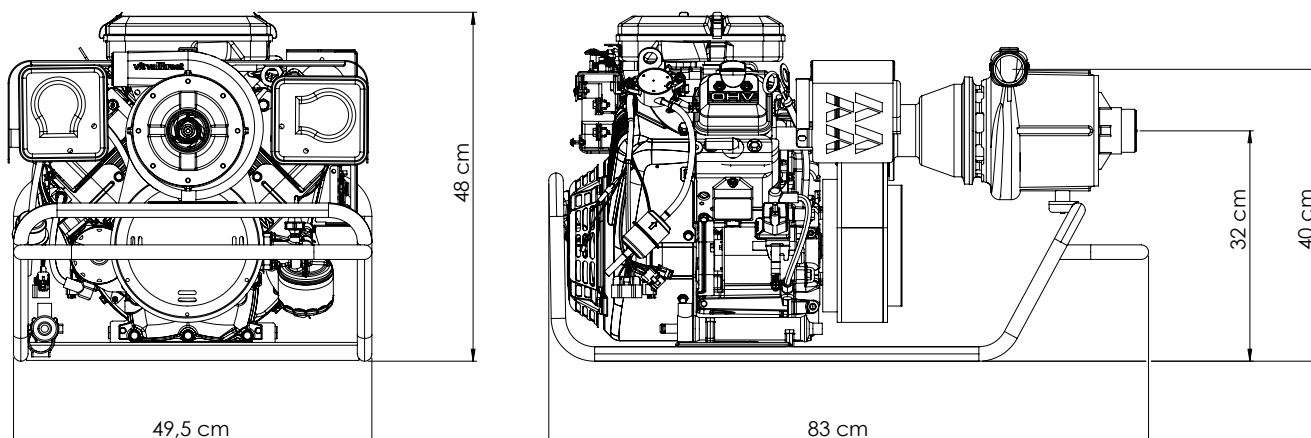

5. Optional Accesories

Foot Valve VFT NH 2"

DVD3105-00001



Thread protector NPSH-NPSH 2"

DVD3108-00001



Thread protector NPSH-NPSH 1-1/2"

DVD3107-00001

Suction Hose 1-1/2" NH

with Foot Valve L=3m

DVD3050-00003

Suction Hose 1-1/2" Storz 52-C

with Foot Valve L=3m

DVD3050-00004



Primer check valve H 1-1/2" NPSH - M 1-1/2"

DVD3113-00001



Fuel Tank 12L

DED6001-00001

Fuel Tank 25L

DED6001-00002



**LíneFuel Line 1/4" for tank
(Mercury female - 1/4" NPT)**

DVD3116-AAA0A



